

DOVETAIL TWISTLOCK 55°

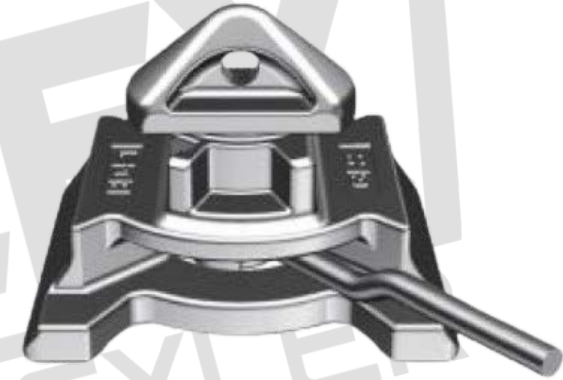
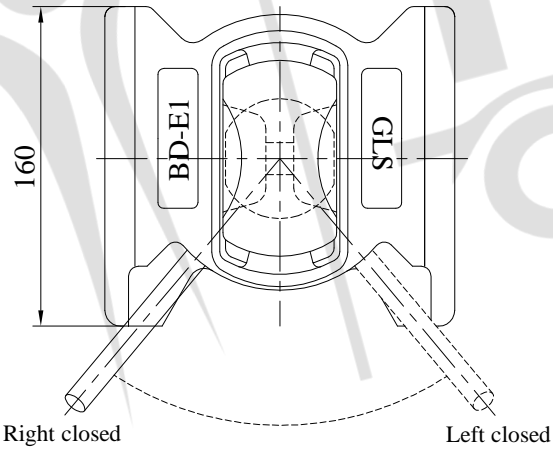
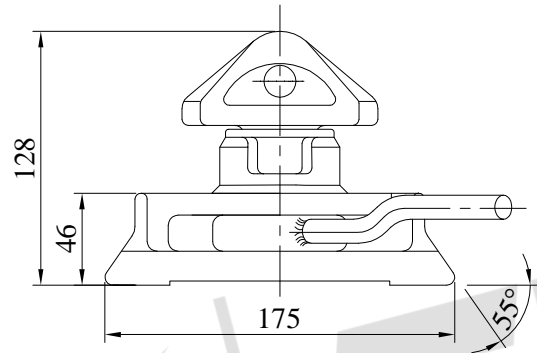

LOADS	SHEAR [KN]	TENSION [KN]
BREAKING LOAD	420	500
SAFE WORKING LOAD	210	250

TOTAL WEIGHT	6.4 KG
MATERIAL	HEAT TREATABLE STEEL
FINISH	HOT DIP GALVANISED

NOTICE:

* TRILEX TREYLER İç ve Dış Tic. Ltd. Şti. has adopted the principle of continuous improvement of its products
 * TRILEX TREYLER reserves the right to make changes in technical dimensions and features without prior notice
 * So; this technical drawing is given to be added to the contract annex and it is for only informational purposes

	Name	Date & Signature	 TRILEX TREYLER İç ve Dış Tic. Ltd. Şti. www.trilex.com.tr www.trilextreyler.com info@trilex.com.tr +90 530 610 1432 / +90 332 239 1860
Designer	A.TAŞDELEN		
Control	A.ADIYAMAN		
Approval	O.ADIYAMAN		
Type Approval	e5*2018/858*00075*00		
Q.M.S. / No.	ISO 9001:2015 / QMS-0104558		
Product Code	TX-SA-SDLT / BD-E1		
Product Name	55° Dovetail / U-Frame Twist Lock		

All rights of this picture belong to TRILEX TREYLER company. So, it can not be reproduced, copied and published without permission