

212-5-7000 C

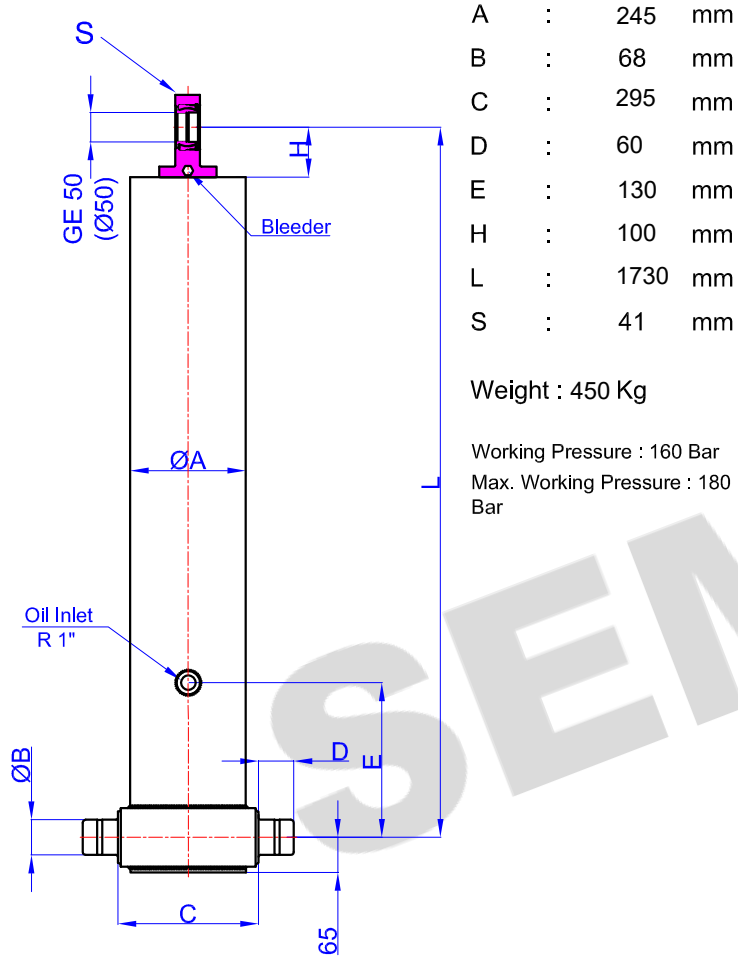

| | | | |
|---|---|------|----|
| A | : | 245 | mm |
| B | : | 68 | mm |
| C | : | 295 | mm |
| D | : | 60 | mm |
| E | : | 130 | mm |
| H | : | 100 | mm |
| L | : | 1730 | mm |
| S | : | 41 | mm |

Weight : 450 Kg

Working Pressure : 160 Bar
Max. Working Pressure : 180 Bar

| STAGE | 1 | 2 | 3 | 4 | 5 | 6 | 7 | 8 | TOTAL |
|--------------------------|------|------|------|------|------|---|---|---|-------|
| EFFECTIVE DIAMETER (mm) | Ø212 | Ø185 | Ø160 | Ø135 | Ø116 | | | | |
| STROKE | 1400 | 1400 | 1400 | 1400 | 1400 | | | | 7000 |
| OIL DISPLACEMENT (L) | | | | | | | | | 210 |
| THRUST AT 160 BAR (TONS) | 45 | 34 | 24 | 18 | 12,5 | | | | |

| BL | 7300 | | | 7100 | | | 6900 | | |
|------|------|------|------|------|------|------|------|------|------|
| Ro | 200 | 500 | 800 | 200 | 500 | 800 | 200 | 500 | 800 |
| α° | 45 | 47 | 50 | 46 | 49 | 51 | 48 | 50 | 53 |
| Ycog | | | | | | | | | |
| 600 | 39 | 42 | 48 | 40 | 44 | 49 | 41 | 45 | 51 |
| 900 | 42 | 47 | 53 | 43 | 49 | 56 | 45 | 51 | 59 |
| 1200 | 46 | 52 | 60 | 48 | 55 | 65 | 50 | 58 | 70 |
| st | 5475 | 5483 | 5583 | 5443 | 5553 | 5525 | 5520 | 5500 | 5565 |

* The Cylinder has only the function of lifting and the equipment and should not be used for this.

* Working pressure depends on the application

* Never exceed the max. working pressure stated.

* Hard Chromed all stages

NOTICE:

- * 'Büyükyüksel Damper Hid. Mak. San. Tic. Ltd. Şti.' has adopted principle of continuous improvement its products
- * 'Büyükyüksel Damper' reserves the right to make changes in technical dimensions and features without prior notice
- * So; this technical drawing is given to be added to the contract annex and it is for only informational purposes

| | Name | Date & Signature |  <p>Trademark Name: SEMİTÜRK</p> <p>www.yukseldamper.com.tr</p> <p>www.semiturk.com.tr</p> <p>info@yukseldamper.com.tr</p> <p>+90 530 610 1432 / +90 332 239 1860</p> |
|---------------|---------------------------------------|------------------|---|
| Designer | A.TAŞDELEN | | |
| Control | A.ADIYAMAN | | |
| Approval | O.ADIYAMAN | | |
| Type Approval | e5*2018/858*00075*00 | | |
| Q.M.S. / No. | ISO 9001:2015 / QMS-0104558 | | |
| Product Code | TX-SA-H5SC-45 (212-5-7000 C) | | |
| Product Name | 5 Stage Hydraulic Cylinder for Tipper | | |

All rights of this picture belong to BÜYÜKYÜKSEL DAMPER LTD. ŞTİ. So, it can not be reproduced, copied and published without permission